



## Applicant Acknowledgement

I, \_\_\_\_\_(print name) here by acknowledge that by attaching this to my signed permit application; that my permit will be issued with only a general plan review provided. I am aware of my responsibility to place the Mobile Home to comply with code requirements. Any deficiency(s) identified at the time of site inspection will be corrected in a timely manner.

\_\_\_\_\_(Signature) I have reviewed this document and confirm my project does not contain any of the items that **require a complete plans review by a Building Safety Codes Officer.**

## Submitted Documentation includes a minimum of:

- New Home Warranty (After February 1 2014)
- site plan
- foundation requirements:
  - wood blocking is acceptable (must be pressure-treated wood within 6" of grade)
  - any other foundation may/will require a structural engineered stamped plan
- floor plan
- 4 elevation views (north, south, east and west)
- C.S.A. number
- Alberta Municipal Affairs number
- proof of deformation resistant building (built on steel frame)

Documentation provided will be reviewed in conjunction with construction at the time of site inspection.

## Application

A **complete plan review by a Building Safety Codes Officer** is required if:

- The Mobile Home is more than one storey in height,
- has any addition(s), or
- if spatial separation to any other building or property line is less than 16'(4.88 m)

## Required Inspections

Required inspection(s) will be printed on your issued permit. It is the responsibility of the applicant to call for all required inspection(s) PRIOR TO COVERING. If you have questions, don't hesitate to get in touch with OUR OFFICE AT (780) 454 5048 or EMAIL US AT [general@inspectionsgroup.com](mailto:general@inspectionsgroup.com)



**NOTE:** Below is a general overview of code requirements that will be emphasized at the time of inspection. Inspection may identify additional requirements as determined by the Safety Codes Officer at time of inspection.

## Code Requirements – National Building Code: Alberta Edition 2019

- 1) Access to the Building: Minimum of a landing (minimum 1100mm width or width of stair, whichever is greater), stairs (minimum width of 860mm) and guards (minimum height of 900mm) shall be provided for access to the building.

Code Origin: Section 9.8., Part 9, Division B

- 2) Resistance to Decay: Where structural wood members (i.e. Wall bottom plates, studs) are vertically located 150mm (6”) or less from the adjacent grade, the wood must be pressure-treated to resist decay.

Code Origin: Sentence 9.3.2.9.(3), Part 9, Division B

- 3) Flame Spread: Interior surfaces cannot have a flame spread rating of greater than 150. Units with particle board panelling **require a complete plan review by a Building Safety Codes Officer.**

Code Origin: Sentence 9.10.14.5.(10), Part 9, Division B

- 4) Foundation: Wood pier foundations must be installed to CSA Z240 standard. Screw pile foundations shall have three pieces of documentation: 1) Pre-engineered drawing with engineer’s stamp from the screw pile manufacturer, 2) Design bearing loads for each screw pile location, from the manufacturer (how much each pile needs to support), and 3) the installers torque logs the specifically identify each screw pile installed and the torque load of each screw pile. Screw pile documentation is all required to be on site at the time of inspection. Any other foundation will require a **complete plan review by a Building Safety Codes Officer.**

Code Origin: Article 9.15.1.3., Part 9, Division B & Article 2.2.13.6., Part 9, Division C



- 5) Smoke Alarms: At least one smoke alarm is required on each storey of a house, and in every hallway that serves a bedroom(s), and within each bedroom. All Smoke alarms installed within a building are required to be interconnected.

Code Origin: Subclause 9.10.19.3.(1)(b)(ii), Part 9, Division B

- 6) Carbon Monoxide (CO) Alarm: A CO alarm needs to be installed either inside each bedroom, or outside the bedroom(s) within five metres (16'-4") of each bedroom door.

Code Origin: Sentence 9.32.3.9.(4), Part 9, Division B

- 7) Bedroom Egress Windows: To allow for safe egress in the event of an emergency, the openable area of the egress window needs to be at least 3.75 ft<sup>2</sup> (0.35 m<sup>2</sup>), and with no dimension (height, length) less than 15" (380mm). This window must be openable from the inside without the use of keys, tools or special knowledge and without the removal of sashes or hardware. Hopper windows are not permissible, must be of an awning, slider, or casement type.

## BEDROOM WINDOW EGRESS

Bedroom windows must be sized so that they can be used as a direction of escape in case of fire. Each bedroom must have a window that opens from the inside without the use of tools or special knowledge and has an unobstructed area when open of at least 0.35 m<sup>2</sup> or 3.75 ft<sup>2</sup>. (minimum dimension of opening, (width or height), allowed is 380mm or 15") (Division B Article 9.7.1.2).

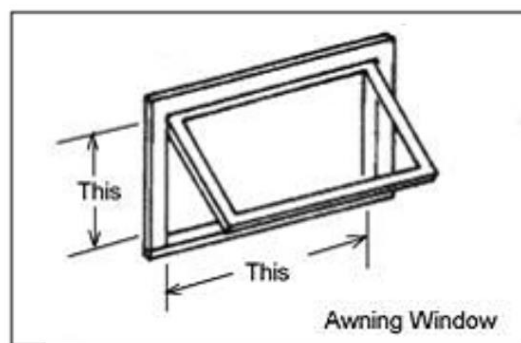
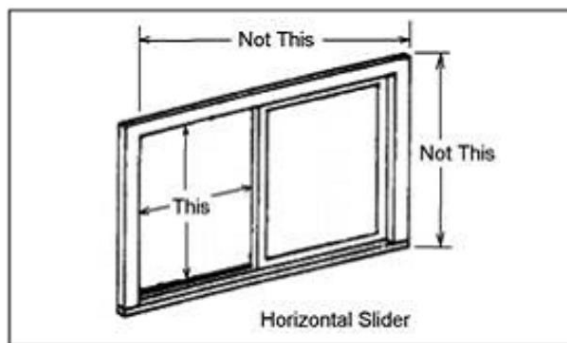

**The critical area of a bedroom window is the open area that is free and clear of obstruction when open fully.**

Code Origin: Article 9.9.10.1., Part 9, Division B

- 8) Ground Cover below home: Ground cover shall be not less than 0.10mm polyethylene,



Code Origin: Sub-Section 9.18.6., Division B, Part 9

- 9) Site Grading: The site shall be graded to drain water away from the building.

Code Origin: Article 9.14.6.1., Division B, Part 9

- 10) Exterior Building Envelope: The exterior envelope needs to ensure that both primary and secondary planes of protection direct water to the exterior, secured and attached correctly, and all penetrations of the building envelope are sealed to prevent the ingress of water and moisture.

Code Origin: Article 9.14.6.1., Division B, Part 9

- 11) Proof of Certification for Off-Site Manufactured Buildings: Off-Site manufactured buildings shall be certified. Building NOT certified to CSA A277 or CSA Z240 are considered uncertified buildings and require a **complete plan review by a Building Safety Codes Officer.**

Code Origin: Sub-Section 2.4.5., Division C, Part 2

Free downloadable PDF copy of the National Building Code: Alberta Edition is available from the National Research Council. <https://nrc-publications.canada.ca/eng/view/ft/?id=3e93ecc7-7ad6-43ff-ac1e-89c0d033b8aa> The PDF is hyperlinked and searchable.